

ASCO™ COIL

SPADE TERMINALS (DIN 46340)

SERIES

ZB..K

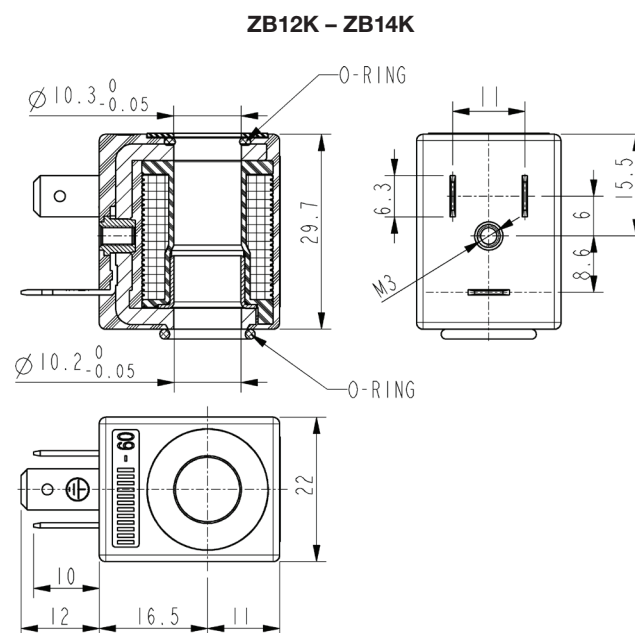
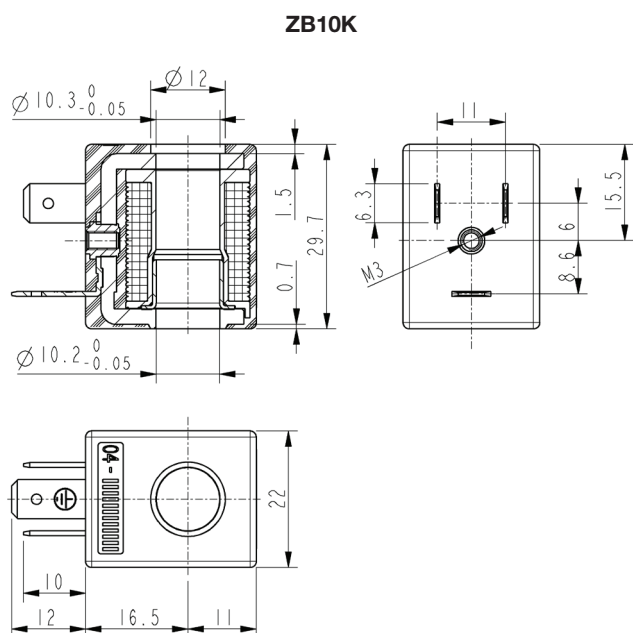

General Features

Designed only for use with L282 series solenoid valves in AC.

Complying with 2014/35/EU (LVD) and 2014/30/EU (EMC) directives.

Product in accordance with the RoHS 2 directive.
100% inspected.

Electric Connections

Spade terminals 6,3 x 0,8 (DIN46340), 2 line + 1 earth terminals.
3 poles plug connector.

Technical Features		ZB10K	ZB12K	ZB14K
Approval		/	UL and CSA	UL and CSA
Encapsulation material		PA (Polyamide) fiberglass reinforced	PET (polyethylene-terephthalate) fiberglass reinforced	PET (polyethylene-terephthalate) fiberglass reinforced
Insulation class		F (155°C)	F (155°C)	H (180°C)
Ambient temperature		-10°C +60°C	-10°C +60°C	-10°C +75°C
Continuous duty		ED 100%		
Electric connection		DIN 46340 - 3 poles plug connector		
Protection degree		IP 65 (EN 60529) with plug connector	IP 67 (EN 60529) with plug connector	IP 67 (EN 60529) with plug connector
Voltages		AC 24V/50-60Hz - 115V/50Hz - 230V/50-60Hz (+10% -15%) (Other voltages and frequencies on request)		

Type	Power absorption			Notes	Weight (kg)
	AC				
	Inrush VA	Holding VA W			
ZB10K				-	0,060
ZB12K	11,7	10	7,6	1 - 2	
ZB14K					

Notes

1 – Fitted with sealing gaskets underneath and on the upper part (see drawing)

2 – UL approval (E153691): 12V/50-60Hz - 24V/50-60Hz - 48V/50-60Hz - 110-120V/50-60Hz - 120V/60Hz - 200V/50-60Hz - 220-230V/50Hz - 208-240V/60Hz - 230V/50-60Hz - 240V/ 50-60Hz