

DESCRIPTION

Encapsulated coil incorporating the magnetic circuit.
 Fixing by means of central nut.
 Electrical connection according to DIN 46244.



CONSTRUCTION

Encapsulation:

Class F Fibre-glass Nylon

Class H Fibre-glass Polyarylamide

Magnetic circuit: Zinc-plated steel

Windings: Copper covered with class H insulation

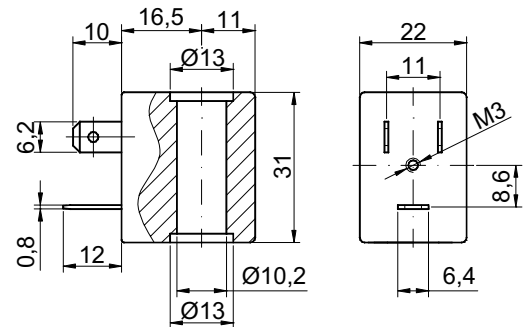

OPTIONS : Electrical connection through cable
 Special coil powers
 Special coil voltages
 Self-extinguish

Certified versions



CODE		Alternating Current Frequency 50/60Hz Voltage Volt	Direct Current Voltage Volt	Power ①		Voltage tolerance		Connector	Service ED
Insulation class F	Insulation class H			Alternating Current VA	Direct Current Watt	Alternating Current	Direct Current		
30A	32A	12	---	8	6.5	+15%	±10%	10348000	100%
30B	32B	24	---						
30C	32C	48	---						
30D	32D	110	---						
30E	32E	220/230	---						
30F	32F	240	---						
30G	32G	380	---			-10%			
300	320	---	12						
301	321	---	24						
302	322	---	48						
/	U35D	120V 60Hz							
/	U35E	230V 60Hz							
/	V32E	220/230							

7

① Considering nominal voltage and an ambient temperature of 20°C