

DESCRIPTION

Solenoid valve 2 way normally closed with servo-assisted piston

CONSTRUCTION

Body and cover	Brass
Armature tube	Stainless steel
Plunger and core	Stainless steel
Springs	Stainless steel
Piston	Brass
Piston seal	PTFE reinforced
Seal material	Main seal PTFE, other FPM



FEATURES

- Minimum differential pressure 1bar
- Maximum allowable pressure PS 60bar^③
- Maximum fluid viscosity 25cSt (mm²/s)
- Ambient temperature: from -10°C to +80°C according to the coil
- Preferred mounting position with vertical coil above

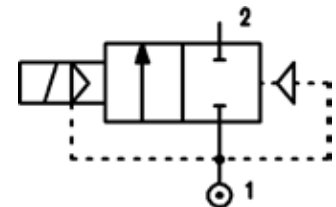

4

OPTIONS: Electroless nickel plating
 us certified coils

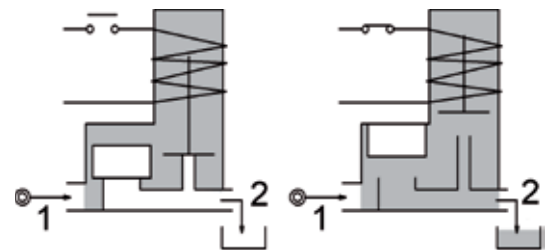

CODE ②	Connection G ISO 228	Orifice mm	Kv m ³ /h	Differential pressure bar			Nominal power			Coil		Seal	Temp. range °C
				Min	Max		AC Inrush	VA Holding	DC Watt	Series	Width		
E119BV52///...	1/4"	5.2	0.47	1.5	50	50	20	15	10	2	30	PTFE/ FPM	-10 +140
E119CV12///...	3/8"	12	2	1	30	30							
E119DV12///...	1/2"	12	2.2	1	30	30	40	30	27	5	36		
E119CV12/1/...	3/8"	12	2	1	50	50							
E119DV12/1/...	1/2"	12	2.2	1	50	50							

② Coil

Example: E119DV12/1/521 FPM seal
 Coil 24V DC
 Maximum differential pressure 50bar

Maximum allowable leakage <0.2NI/h

③ **REMARK**

The maximum allowable pressure PS for steam 2,5bar (gauge pressure)

COILS	Alternating Current 50/60Hz Volt							Direct Current Volt			Electrical connection	Connectors
	12	24	48	110	220 230	240	380	12	24	48		
Series 2 Width 30 Code ②	20A	20B	20C	20D	20E	20F	20G	200	201	202	DIN 43650A	PG9 code 10349000
Series 5 Width 36 Code ②	52A	52B	52C	52D	52E	52F	52G	520	521	522	DIN 43650A	PG11 code 10349001

DESCRIPTION
 Insulation class
 Series 2 =F Series 5=H
 Voltage tolerance
 AC +15% -10%
 DC ± 10%
 Protection class
 IP65 with connector fitted
 IP00 without connector
 Continuous service ED100%

OPTIONS
 Class H insulation (series 2)
 Cable attached
 Special coil voltage
 Special coil powers
 CE certified coils

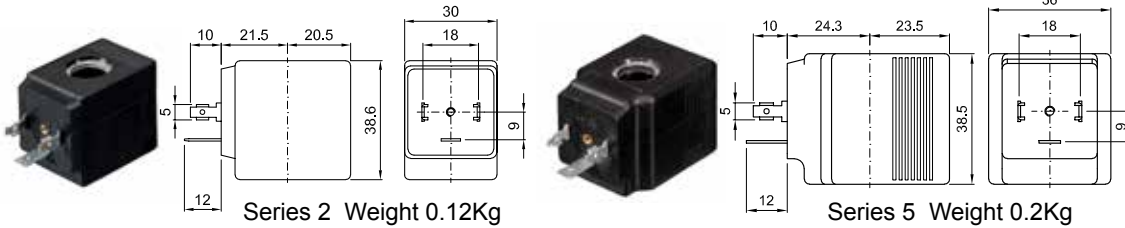

SPARE PARTS LIST

1. Coil fixing nut
2. Coil
3. Plunger
4. Armature tube with core
5. Piston assembly

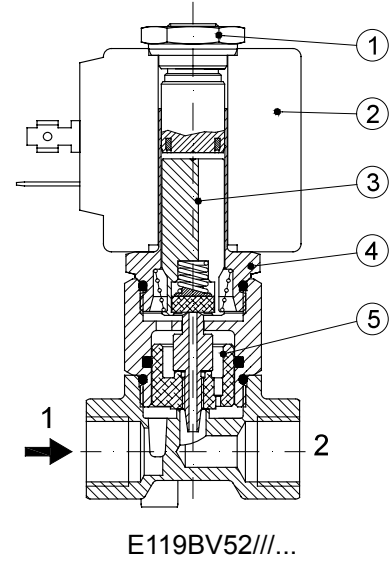
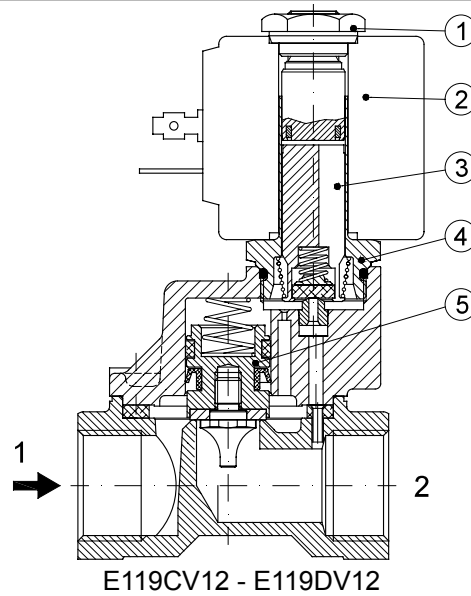

OVERALL DIMENSION

Weight with coil series 2=0.63Kg
 Weight with coil series 5=0.71Kg

